

fundisa.net



METRO CENTRAL EDUCATION DISTRICT

GRADE 12

**PHYSICAL SCIENCES PAPER 1 (PHYSICS)
COMMON CLUSTER SEPT/OCT 2020 EXAMINATION**

MARKS: 150

TIME: 3 hours

This question paper consists of 18 pages and 3 data sheets.

INSTRUCTIONS AND INFORMATION

1. Write your name on the first page of your ANSWER BOOK.
2. This question paper consists of TEN questions. Answer ALL the questions in the ANSWER BOOK.
3. Start EACH question on a NEW SIDE of your RULED A4 PAPER. Use BOTH sides of the page in order to avoid wasting paper.
4. Number the answers correctly according to the numbering system used in this question paper.
5. Leave ONE line between two sub-questions, for example between QUESTION 2.1 and QUESTION 2.2.
6. You may use a non-programmable calculator.
7. You may use appropriate mathematical instruments.
8. You are advised to use the attached DATA SHEETS.
9. Show ALL formulae and substitutions in ALL calculations.
10. Round off your final numerical answers to a **minimum of TWO decimal places**. In multi-step calculations, intermediate steps, round off to four decimal places.
11. Give brief motivations, discussions, et cetera where required.
12. Write neatly and legibly.

QUESTION 1: MULTIPLE-CHOICE QUESTIONS

Four options are provided as possible answers to the following questions. Each question has only ONE correct answer. Choose the answer and write only the letter (A – D) next to the question numbers (1.1 – 1.10) on your RULED A4 PAPER, for example 1.11 D.

- 1.1 Susan (weight 750 N) stands in a stationary lift on a bathroom scale, which is calibrated in newtons. The lift starts to move, and during the first part of the movement the reading on the scale is larger than 750 N. Which ONE of the following combinations best describes the direction of motion and the acceleration of the lift during this part of the motion?

	Direction of motion	Acceleration
A	Upward	Upward
B	Downward	Downward
C	Upward	Downward
D	Downward	Zero

(2)

- 1.2 An small object is thrown vertically upwards. The velocity-time graph below represents the motion of the object during the time interval from 0 to $3t$ seconds.

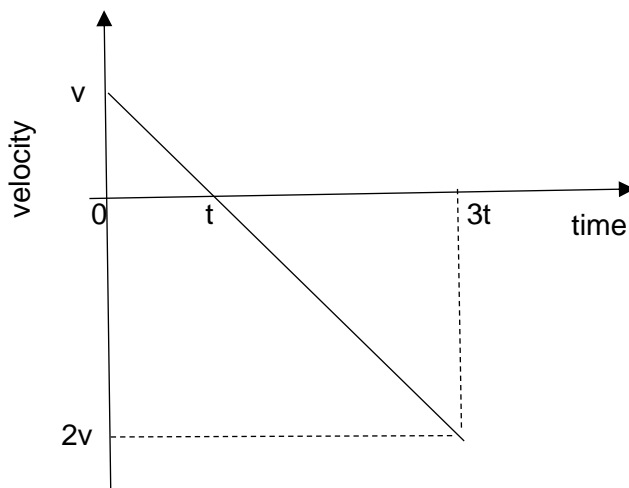

What is the magnitude of the resultant/net displacement over the period 0 to $3t$?

- A $\frac{3}{2}vt$
 B $\frac{1}{2}vt$
 C $\frac{5}{2}vt$
 D $2vt$

(2)

- 1.3 A ball is thrown vertically upwards. Which ONE of the following combinations of the physical quantities has non-zero values at the maximum height?

	QUANTITY 1	QUANTITY 2
A	Velocity	Acceleration
B	Momentum	Velocity
C	Kinetic energy	Gravitational potential energy
D	Weight	Acceleration

(2)

- 1.4 The graph below represents the change in force with time for a tennis ball that is thrown towards a tennis player and struck by the player in the opposite direction.

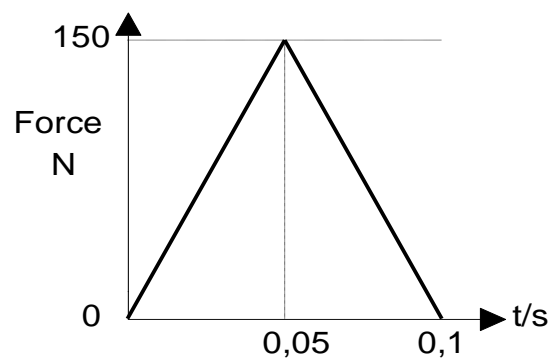

The area under the graph would give the ...

- A change in kinetic energy of the tennis ball
- B impulse experienced by the tennis ball
- C power dissipated on the tennis ball
- D momentum of the tennis ball

(2)

- 1.5 The diagram below shows a track, **ABC**. The curved section, **AB**, is frictionless. The rough horizontal section, **BC**, is 8 m long.

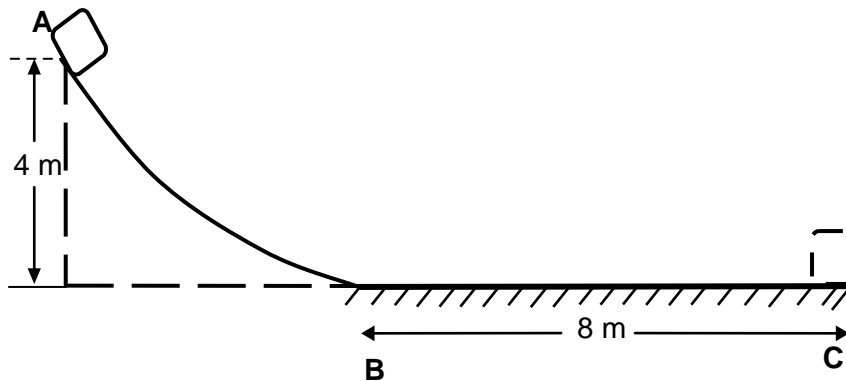

An object of mass 10 kg is released from point **A** which is 4 m above the ground. It slides down the track and comes to rest at point **C**. Which ONE of the following statements about the mechanical energy of the 10 kg mass is CORRECT if it loses energy along BC?

The mechanical energy of the 10 kg mass ...

- A remains constant in section **B** to **C**.
- B at **A** is greater than the mechanical energy at **B**.
- C at **A** is equal to the mechanical energy at **B**.
- D is conserved from **B** to **C**, but is not conserved from **A** to **B**. (2)

- 1.6 The pressure versus time graph below represents a sound wave in air emitted by a stationary source.

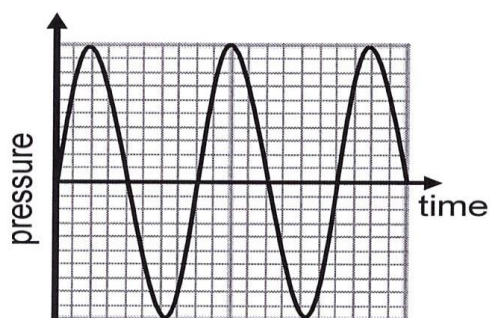

Which ONE of the following graphs best represents the sound wave, as observed by a stationary observer, if the source is moving away from the observer?

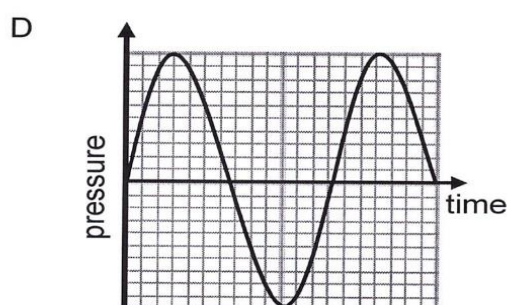
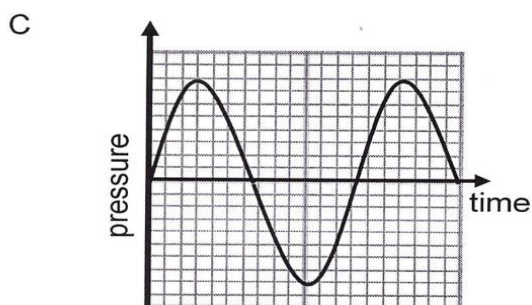
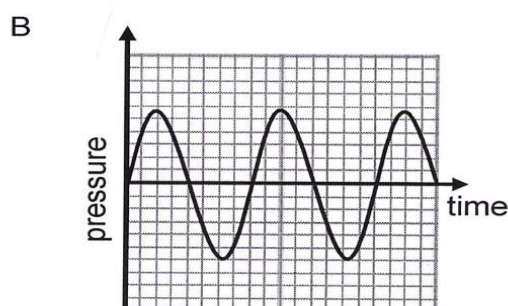
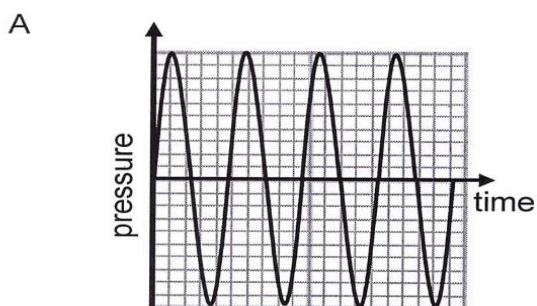

(2)

- 1.7 The magnitude of the electrostatic force on a charge Q_1 due to another charge Q_2 is F . The distance between charges Q_1 and Q_2 is r . One of the charges is now doubled and the distance between the charges is halved.

The magnitude of the electrostatic force that Q_2 now exerts on Q_1 will be:

A $\frac{1}{2}F$

B F

C $4F$

D $8F$

(2)

1.8 The three resistors in the circuit diagram shown below are identical.

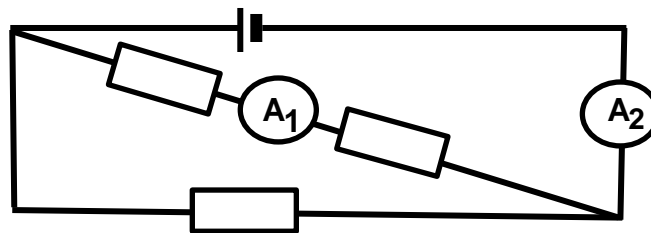

If the reading on the ammeter A_1 is I , what will be the reading on ammeter A_2 ?

A $\frac{1}{2} I$

B $3I$

C $2I$

D I

(2)

1.9 In the diagram below, a straight current carrying conductor, Z, lies between two magnets X and Y. The conductor experiences a downward force when placed between the two magnets.

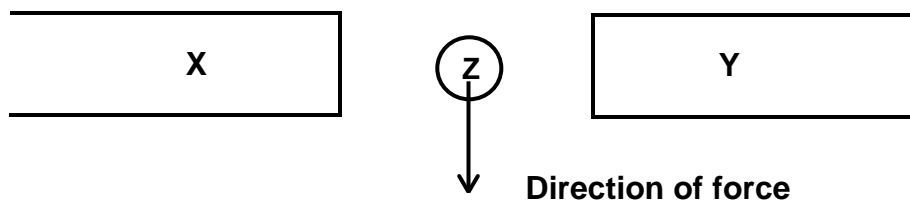

Which ONE of the following combinations is correct?

	Direction of the magnetic field due to X and Y	Direction of the current in Z
A	X to Y	Perpendicular into the page
B	X to Y	Perpendicular out of the page
C	Y to X	Perpendicular into the page
D	Y to X	Opposite direction to the force

(2)

- 1.10 The graph below shows the relationship between the kinetic energy of the ejected photo-electrons and the frequency of the incident radiation.

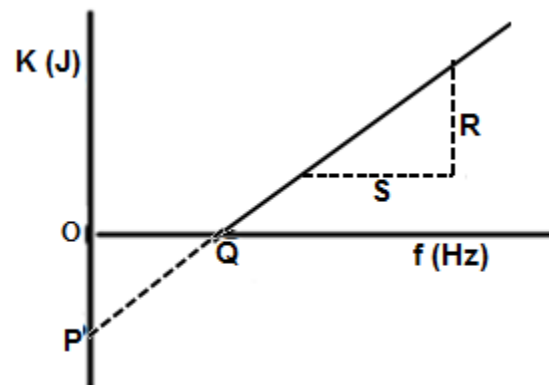

Which ONE of the following set correctly shows the information provided by P, Q, and the ratio of R and S?

	P	Q	$\frac{R}{S}$
A	Negative of Work function	Planck's constant	Threshold frequency
B	Threshold frequency	Work function	Planck's constant
C	Negative of work function	Threshold frequency	Planck's constant
D	E_k of electrons when $f = 0$	Threshold frequency	Work function

(2)
[20]

QUESTION 2 [START ON A NEW PAGE]

- 2.1 Two blocks, A of mass 15 kg and B of unknown mass, m kg, are connected by a light inextensible (inelastic) string on a rough surface. A force of magnitude 120 N is applied to block A at an angle of 30° to the horizontal as shown in the diagram below.

The coefficient of friction for the surface, for both objects is 0,20 and the system accelerates to the right at $2,08 \text{ m}\cdot\text{s}^{-2}$.

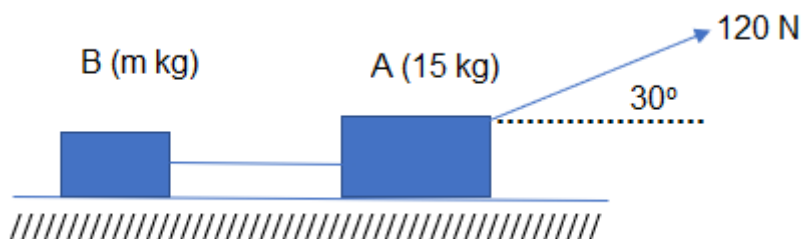

- 2.1.1 State *Newton's Second Law* of motion in words. (2)
- 2.1.2 Draw a fully labelled free-body diagram of ALL the forces acting on block A. (5)
- 2.1.3 Show that the frictional force experienced by block A, while accelerating is 17,4 N. (4)
- 2.1.4 Calculate the tension force in the string between block A and B. (4)
- 2.2 Consider a satellite with mass 1 200 kg orbiting Earth. The distance between the centre of the satellite and the surface of the earth is 36 000 km.

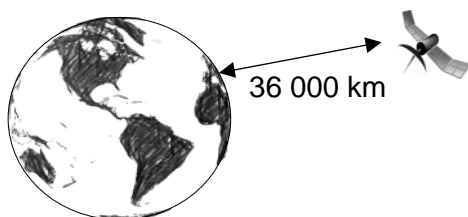

- 2.2.1 State *Newton's universal gravitational law*, in words. (2)
- 2.2.2 Calculate the magnitude of the force that the Earth exerts on the satellite. (4)
- 2.2.3 How will the force that the satellite exerts on the Earth compare to the answer to QUESTION 2.2.2? Write only GREATER THAN, LESS THAN or EQUAL TO. (1)

[22]

QUESTION 3 [START ON A NEW PAGE]

A hard, plastic toy car 0,6 m high from the ground, is placed next to a block of flats. A child leans over the edge of the roof of the building, 21 m above the roof of the car. The child throws a tennis ball, with a mass 73 g, vertically upwards. The tennis ball moves upwards to point X, falls back past the top of the building and hits the roof of the car after 3,77 s. Ignore all the effects of air resistance. Take UPWARD motion as POSITIVE.

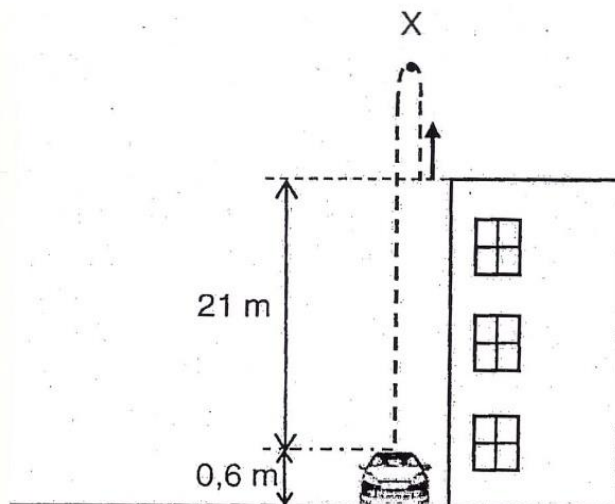

3.1 Is the tennis ball, while it is moving downwards towards the car, in *free fall*? Write down YES or NO. Give a reason for the answer. (2)

3.2 Calculate the:

3.2.1 magnitude of the velocity with which the tennis ball was thrown upwards. (3)

3.2.2 maximum height that the tennis ball will reach above the ground. (4)

3.3 The tennis ball strikes the roof of the parked car with a speed of $24,04 \text{ m}\cdot\text{s}^{-1}$. Assume the roof does not get dented. The tennis ball bounces INELASTICALLY on the roof where the rebound speed of the tennis ball is 25% lower than the speed which the tennis ball strikes the roof of the car. The tennis ball is in contact with the roof of the car for 0,1 s. Calculate the impulse of the tennis ball on the roof of the car. (4)

3.4 Sketch a velocity versus time graph for the motion of the tennis ball from the instant it is thrown vertically upwards until it bounces off the roof of the car and reaches its highest point.

Indicate the following on the graph:

- Time taken to reach the roof of the car,
- Time at which it leaves the roof of the car
- The velocity when thrown upwards,
- Velocity when it strikes the roof of the car
- Velocity when it bounces off the roof of the car

(5)
[18]

QUESTION 4 [START ON A NEW PAGE]

A metal sphere of mass m , is suspended from a chain at a height of h , above the ground, at position **A**. The sphere is held in position **A** by means of an electromagnet as shown in the sketch below. When the electromagnet is switched off, the sphere swings down and moves past position **B**, the lowest position of its trajectory, at $2 \text{ m}\cdot\text{s}^{-1}$, striking a stationary crate, **X**, of 2 kg mass. Ignore ALL friction forces.

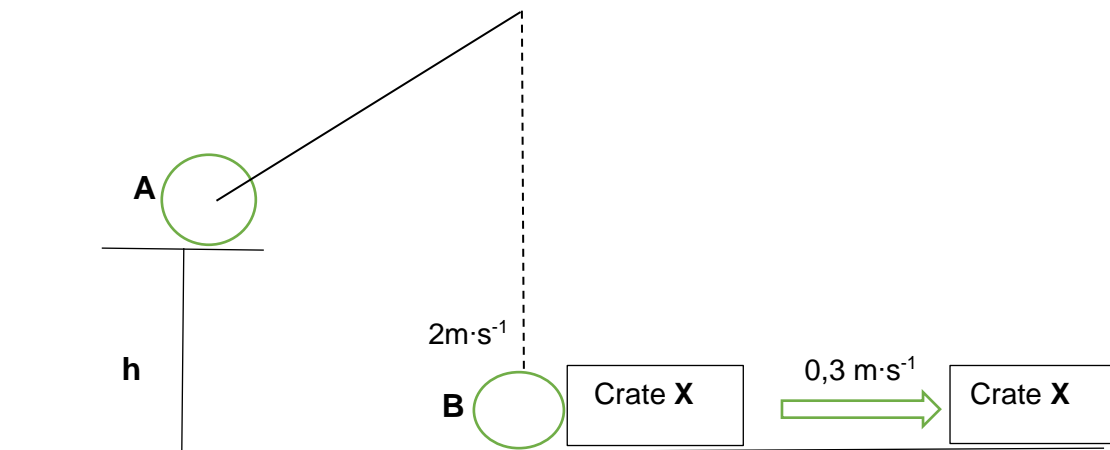

The potential energy (E_p) versus kinetic energy (E_k) graph below represents the motion of the metal sphere from position **A** to position **B**. The angle of inclination of the graph is 135° as shown below.

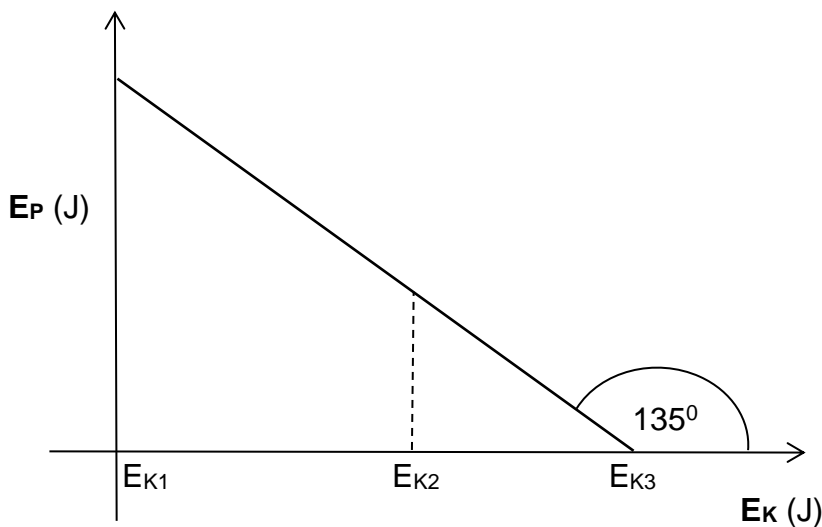

- 4.1 Show that the gradient of the graph can be given by $-\frac{2gh}{v^2}$, where
- g is the gravitational acceleration on earth
 - h is the initial height from which sphere is released
 - v is final velocity of sphere at point B
- (2)
- 4.2 At which point on the graph is the **mechanical energy** of the metal sphere equal to the kinetic energy? Choose from E_{k1} , E_{k2} or E_{k3} .
- (1)
- 4.3 Use the information on the graph and show that the height, h , from which the metal sphere is released, is $0,2 \text{ m}$.
- (2)

- 4.4 If the work done by the conservative force on the metal sphere is 19,6 J, determine the mass **m** of the metal sphere, by using energy principals. (3)

At the lowest point of its motion, the metal sphere collides with a stationary crate **X** of mass 2 kg. After the collision, the crate moves horizontally to the right at a speed of $0,3 \text{ m}\cdot\text{s}^{-1}$.

- 4.5 Determine the velocity of the metal sphere immediately after the collision. (4)
[12]

QUESTION 5 [START ON A NEW PAGE]

Carla wants to investigate the relationship between the work done by the net force and the kinetic energy on her. She slides down a rough incline plane from rest using different masses of trolleys as shown in the diagram below. The unknown mass of Carla is **m**.

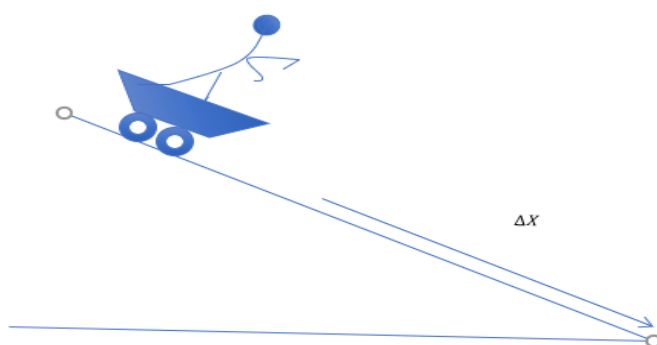

She performs this investigation using trolleys of different masses and recorded the results as shown in the table below.

NUMBER OF TRIALS	NET FORCE (N)	Δv^2 ($\text{m}\cdot\text{s}^{-2}$)	MASS OF DIFFERENT TROLLEYS (kg)
Trial 1	169,41	5,76	30
Trial 2	642,47	0	47
Trial 3	442,91	13,69	40

- 5.1 Which ONE of the trials shows an incorrect? Give a reason for your answer (2)
- 5.2 Use an appropriate equation to describe the relationship between net force and Δv^2 . (2)
- 5.3 State the *work-energy theorem* in words. (2)
- 5.4 Use energy principles to calculate the mass, **m**, of Carla. (6)
[12]

QUESTION 6 [START ON A NEW PAGE]

The Doppler effect is applicable to both sound and light waves. It also has very important applications in our daily lives.

An observer at rest near the tunnel entrance can use Doppler effect to detect the speed of an ambulance. An ambulance approaches a tunnel in a mountain at a constant velocity. A stationary observer hears or detects the frequency of a moving ambulance as 1 204,16 Hz, which is 1,0625 times the actual frequency of the sound emitted by the ambulance. Take the speed of sound in air as $340 \text{ m}\cdot\text{s}^{-1}$.

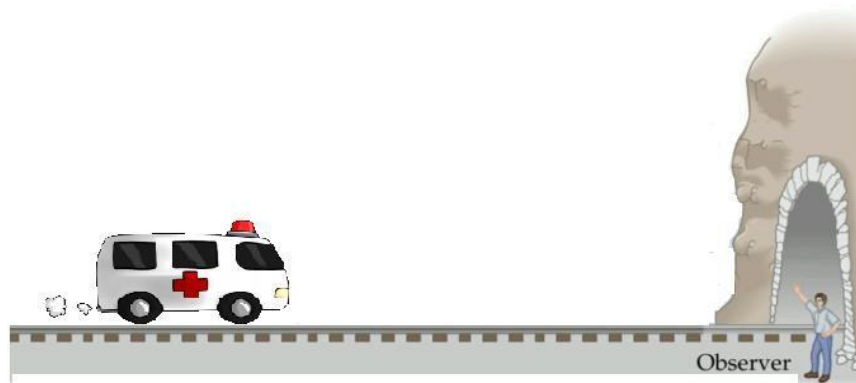

- 6.1 State the *Doppler effect* in words. (2)
- 6.2 Calculate the speed at which the ambulance approaches the stationary observer near the tunnel entrance. (4)
- 6.3 Explain why the measured frequency is higher than the frequency of the source. (2)
- 6.4 How would the frequency of 1 204,16 Hz, detected by the stationary observer, change if the speed calculated in QUESTION 6.2 increases?
Choose from INCREASES, DECREASES or REMAINS THE SAME. (1)
- [9]**

QUESTION 7 [START ON A NEW PAGE]

- 7.1 Two point charges **P** and **S** are placed a distance 0,1 m apart. The charge on **P** is +1,5 nC and that on **S** is -2 nC. A third point charge, **R**, with an unknown positive charge, is placed 0,2 m to the right of point charge **S**, as shown in the diagram below.

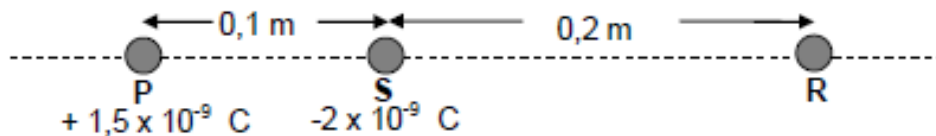

- 7.1.1 State *Coulomb's Law* in words. (2)
- 7.1.2 Draw a labelled free-body diagram showing the electrostatic forces acting on **R** due to **P** and **S**. (2)
- 7.1.3 Calculate the magnitude of the charge on **R**, if it experiences a net electrostatic force of $1,27 \times 10^{-6}$ N to the left. Take the right direction as positive. (5)
- 7.2 Point **P** is 0,5 m from charged sphere **A**. The electric field strength at **P** is 3×10^7 N·C⁻¹ directed towards **A**. Refer to the diagram below.

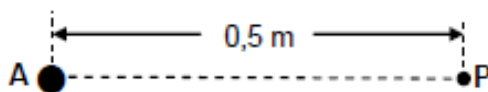

- 7.2.1 Draw the electric field pattern due to the charged sphere **A**. (2)
- 7.2.2 Calculate the magnitude of the charge on sphere **A**. (3)

Another charged sphere **B**, having a charge of $-1,6 \times 10^{-14}$ C is now placed at a point, 0,2 m to the right of point **P**.

- 7.2.3 Calculate the magnitude of the net electric field experienced at point **P**. (5)

[19]

QUESTION 8 [START ON A NEW PAGE]

8.1 Grade 12 learners are conducting an experiment to determine the INTERNAL RESISTANCE of a battery. The learners were divided into two groups:.

Group 1 used battery 1 with an internal resistance r_1

Group 2 used battery 2 with an internal resistance r_2

The results of each group are shown in the graph below.

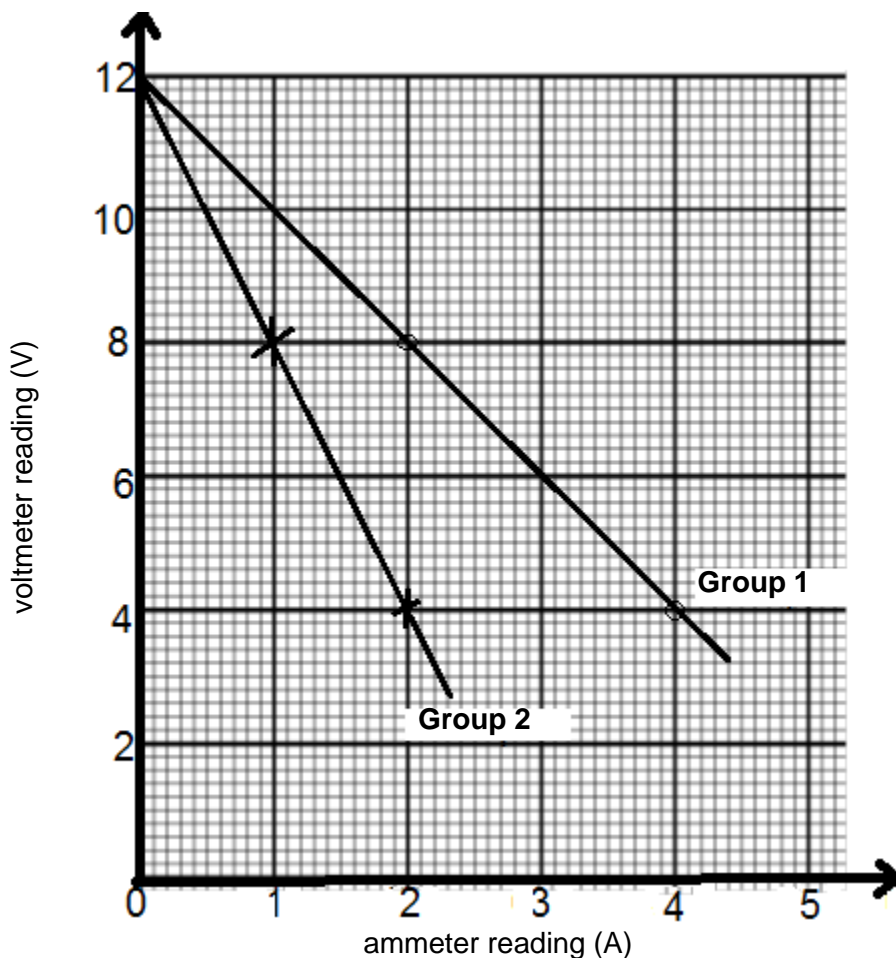

- 8.1.1 Explain why the voltmeter reading across the battery decreases as the current increases. Use appropriate equation(s) in physics in your explanation. (3)
- 8.1.2 Which group, 1 or 2, used a battery with greater internal resistance? (1)
- 8.1.3 Use the graph to determine the internal resistance of the battery used by learners in group 1. (3)

- 8.2 In the circuit diagram below, resistor R_1 is rated at 6 W and resistor R_2 has a resistance of 10Ω . X is a resistor with an unknown resistance. The resistance of the switch, ammeter and connecting wires are negligible, while the voltmeters have a very high resistance. The *emf* of the battery is 18 V and its internal resistance r is unknown.

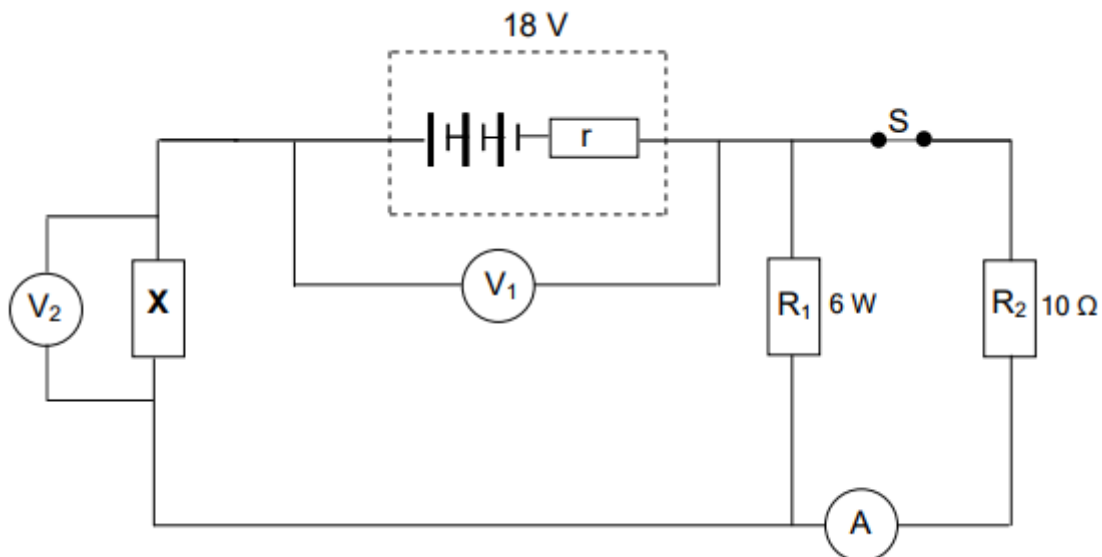

When switch **S** is **closed**, the ammeter **A**, reads 1,2 A while voltmeter **V₂** reads 3,8 V.

- 8.2.1 Explain what is meant by “*The emf of the battery is 18 V*”, as stated above. (2)
- 8.2.2 If the internal resistance, r , is $1,29 \Omega$, calculate the resistance of resistor **X**. (6)
- 8.2.3 Switch **S** is now **opened**. How will the reading on each of the following voltmeters be affected? State only **INCREASES**, **DECREASES** or **REMAINS CONSTANT**.
- (a) voltmeter **V₁** (1)
- (b) voltmeter **V₂** (1)
- [17]

QUESTION 9 [START ON A NEW PAGE]

- 9.1 The diagrams below illustrate a generator with a rotating coil, between magnetic poles, shown in a number of different positions labelled **A – E**. The coil is rotated clockwise at constant speed in a uniform magnetic field.

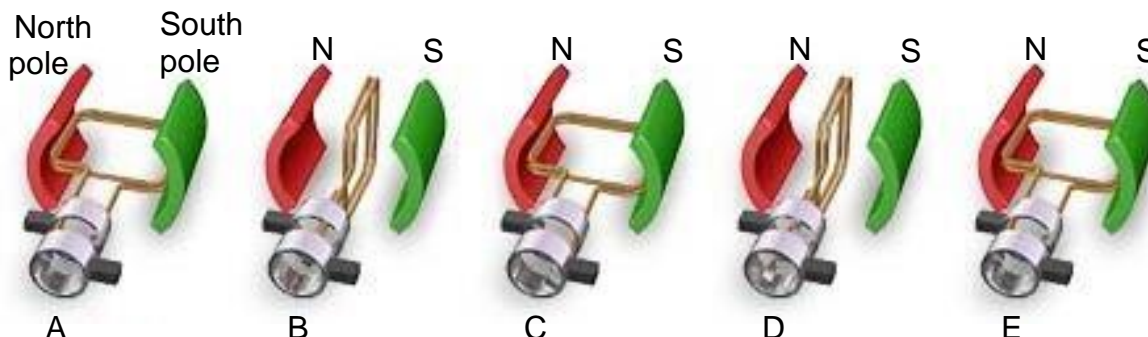

- 9.1.1 On which principle is the working of the generator based? (1)
- 9.1.2 Write down the energy conversion that takes place while the generator is in operation. (1)
- 9.1.3 A student states that the diagrams illustrate an AC generator. Give a reason why this statement is correct. (1)
- 9.1.4 Sketch a graph to show how the induced emf of the generator varies with time. Clearly indicate positions A, B, C, D and E on the graph to correspond to the diagrams. (2)
- 9.2 The graph of potential difference and time for the generator in QUESTION 9.1 is shown below.

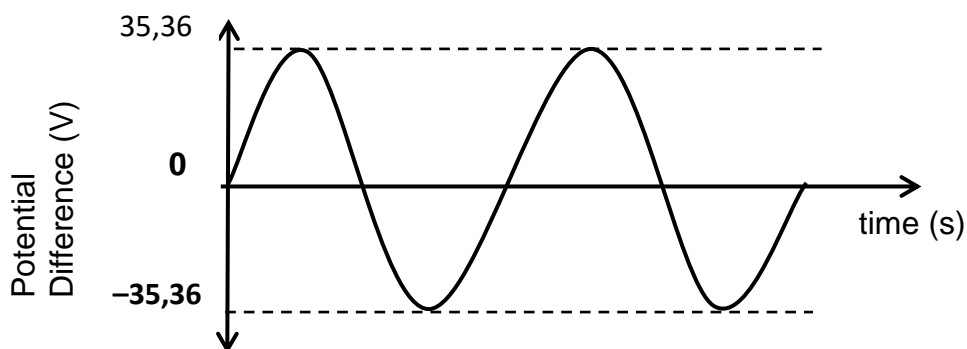

If an rms current of 1,22 A is produced, determine the rate at which the generator will transfer energy.

(4)
[9]

QUESTION 10 [START ON A NEW PAGE]

- 10.1 An electroscope with a negatively charged zinc plate is shown below. The gold leaf is deflected due to the like charges repelling each other.

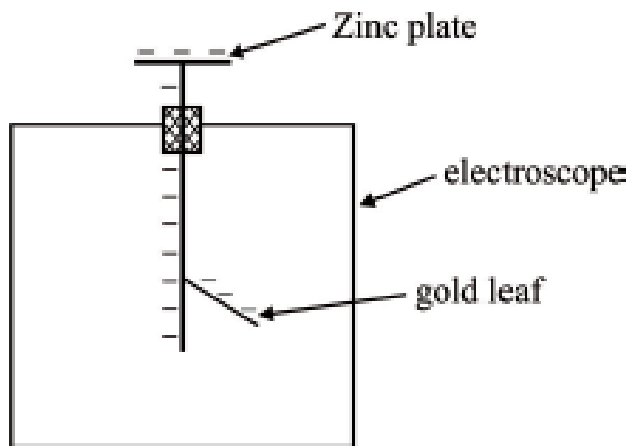

When the plate is irradiated with visible light, nothing is observed.
When the plate is irradiated with ultraviolet light the gold leaf collapses.

- 10.1.1 Name the phenomenon observed. (1)
- 10.1.2 Explain why visible light has no effect on the gold leaf, but ultraviolet light collapses the gold leaf. (2)
- 10.2 The work-function of caesium is $3,36 \times 10^{-19}$ J.
- 10.2.1 Define in words the term *work-function*. (2)
- 10.2.2 Calculate the lowest frequency photons should have to eject electrons from caesium. (3)
- 10.2.3 Calculate the maximum kinetic energy of an electron ejected from caesium by a photon of light of wavelength of 400 nm. (4)
- [12]**

**DATA FOR PHYSICAL SCIENCES GRADE 12
PAPER 1 (PHYSICS)**

**GEGEWENS VIR FISIESTE WETENSAPPE GRAAD 12
VRAESTEL 1 (FISIKA)**

TABLE 1: PHYSICAL CONSTANTS/TABEL 1: FISIESTE KONSTANTES

NAME/NAAM	SYMBOL/SIMBOOL	VALUE/WAARDE
Acceleration due to gravity <i>Swaartekragversnelling</i>	g	9,8 m·s ⁻²
Universal gravitational constant <i>Universele gravitasiekonstant</i>	G	6,67 x 10 ⁻¹¹ N·m ² ·kg ⁻²
Speed of light in a vacuum <i>Spoed van lig in 'n vakuum</i>	c	3,0 x 10 ⁸ m·s ⁻¹
Planck's constant <i>Planck se konstante</i>	h	6,63 x 10 ⁻³⁴ J·s
Coulomb's constant <i>Coulomb se konstante</i>	k	9,0 x 10 ⁹ N·m ² ·C ⁻²
Charge on electron <i>Lading op elektron</i>	e ⁻	-1,6 x 10 ⁻¹⁹ C
Electron mass <i>Elektronmassa</i>	m _e	9,11 x 10 ⁻³¹ kg
Mass of the Earth <i>Massa van die Aarde</i>	M	5,98 x 10 ²⁴ kg
Radius of the Earth <i>Radius van die Aarde</i>	R _E	6,38 x 10 ⁶ m

TABLE 2: FORMULAE/TABEL 2: FORMULES**MOTION/BEWEGING**

$v_f = v_i + a \Delta t$	$\Delta x = v_i \Delta t + \frac{1}{2} a \Delta t^2$ or/of $\Delta y = v_i \Delta t + \frac{1}{2} a \Delta t^2$
$v_f^2 = v_i^2 + 2a\Delta x$ or/of $v_f^2 = v_i^2 + 2a\Delta y$	$\Delta x = \left(\frac{v_i + v_f}{2} \right) \Delta t$ or/of $\Delta y = \left(\frac{v_i + v_f}{2} \right) \Delta t$

FORCE/KRAG

$F_{\text{net}} = ma$	$p = mv$
$f_s^{\text{max}} = \mu_s N$	$f_k = \mu_k N$
$F_{\text{net}} \Delta t = \Delta p$ $\Delta p = mv_f - mv_i$	$w = mg$
$F = G \frac{m_1 m_2}{d^2}$ or/of $F = G \frac{m_1 m_2}{r^2}$	$g = G \frac{M}{d^2}$ or/of $g = G \frac{M}{r^2}$

WORK, ENERGY AND POWER/ARBEID, ENERGIE EN DRYWING

$W = F \Delta x \cos \theta$	$U = mgh$ or/of $E_p = mgh$
$K = \frac{1}{2} mv^2$ or/of $E_k = \frac{1}{2} mv^2$	$W_{\text{net}} = \Delta K$ or/of $W_{\text{net}} = \Delta E_k$ $\Delta K = K_f - K_i$ or/of $\Delta E_k = E_{kf} - E_{ki}$
$W_{\text{nc}} = \Delta K + \Delta U$ or/of $W_{\text{nc}} = \Delta E_k + \Delta E_p$	$P = \frac{W}{\Delta t}$
$P_{\text{ave}} = Fv_{\text{ave}}$ / $P_{\text{gemid}} = Fv_{\text{gemid}}$	

WAVES, SOUND AND LIGHT/GOLWE, KLANK EN LIG

$v = f \lambda$	$T = \frac{1}{f}$
$f_L = \frac{v \pm v_L}{v \pm v_s} f_s$ $f_L = \frac{v \pm v_L}{v \pm v_b} f_b$	$E = hf$ or/of $E = h \frac{c}{\lambda}$
$E = W_o + E_{k(\text{max})}$ or/of $E = W_o + K_{\text{max}}$ where/waar	
$E = hf$ and/en $W_o = hf_o$ and/en $E_{k(\text{max})} = \frac{1}{2} mv_{\text{max}}^2$ or/of $K_{\text{max}} = \frac{1}{2} mv_{\text{max}}^2$	

ELECTROSTATICS/ELEKTROSTATIKA

$F = \frac{kQ_1Q_2}{r^2}$	$E = \frac{kQ}{r^2}$
$V = \frac{W}{q}$	$E = \frac{F}{q}$
$n = \frac{Q}{e}$ or / of $n = \frac{Q}{q_e}$	

ELECTRIC CIRCUITS/ELEKTRIESE STROOMBANE

$R = \frac{V}{I}$	emf (ϵ) = I(R + r) emk (ϵ) = I(R + r)
$R_s = R_1 + R_2 + \dots$ $\frac{1}{R_p} = \frac{1}{R_1} + \frac{1}{R_2} + \dots$	$q = I \Delta t$
$W = Vq$ $W = VI \Delta t$ $W = I^2R \Delta t$ $W = \frac{V^2 \Delta t}{R}$	$P = \frac{W}{\Delta t}$ $P = VI$ $P = I^2R$ $P = \frac{V^2}{R}$

ALTERNATING CURRENT/WISSELSTROOM

$I_{rms} = \frac{I_{max}}{\sqrt{2}}$ / $I_{wgk} = \frac{I_{maks}}{\sqrt{2}}$	$P_{ave} = V_{rms} I_{rms}$ / $P_{gemiddeld} = V_{wgk} I_{wgk}$
$V_{rms} = \frac{V_{max}}{\sqrt{2}}$ / $V_{wgk} = \frac{V_{maks}}{\sqrt{2}}$	$P_{ave} = I_{rms}^2 R$ / $P_{gemiddeld} = I_{wgk}^2 R$
	$P_{ave} = \frac{V_{rms}^2}{R}$ / $P_{gemiddeld} = \frac{V_{wgk}^2}{R}$